

Chg.	Date
31	08-18
32	02-19

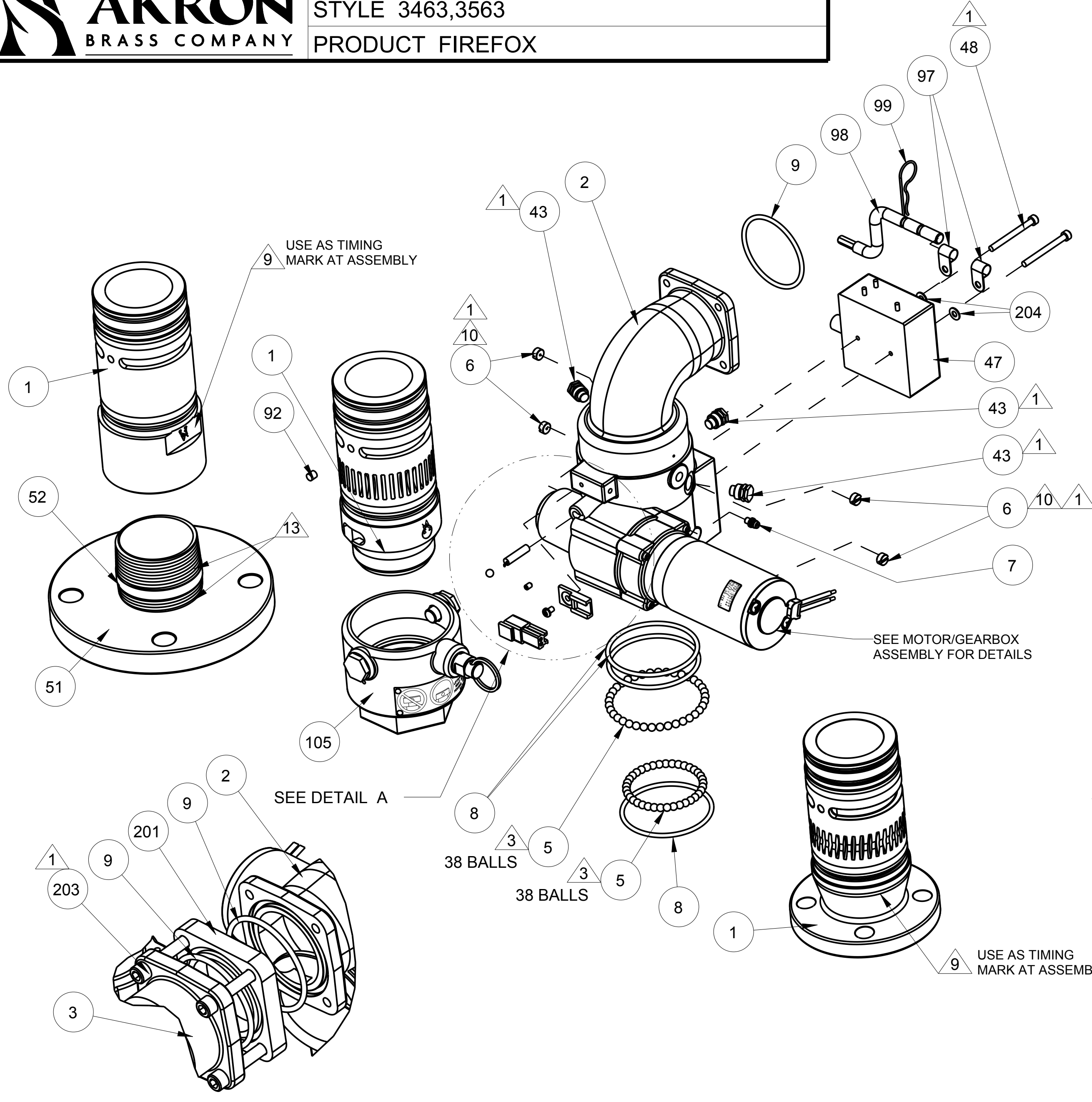

- ASSEMBLY NOTES:
- 1 USE PERMABOND LM113 OR LOCTITE 222
 - 2 USE LOCTITE 290
 - 3 USE LOW-TEMP LUBRIPLATE
 - 4 USE SIKAFLEX-1A SEALANT
 - 5 DIMPLE AT ASSEMBLY
 - 6 GENERIC DEPICTION. SEE BILL OF MATERIALS
 - 7 USE ONLY ON U1 VERSIONS (34632XXX DENOTES U2 VERSIONS)
 - 8 USE PERMABOND LH050 OR LOCTITE 592
 - 9 ALIGN TIMING DIMPLE ON BOTH JOINTS
 - 10 ALIGN BALL IN HOLE. TIGHTEN PLUG UNTIL IT TOUCHES BALL. THEN BACK OUT PLUG 1/4-1/2 TURN.
 - 11 THIS ITEM NOT USED ON VERSION WITH DRY CHEMICAL NOZZLE. SEE DRY CHEMICAL ASSEMBLY DRAWING (D-41621) FOR INSTALLATION/ASSEMBLY DETAILS.
 - 12 CUT WIRES AT CONNECTOR AND SEAL WITH SIKAFLEX-1A SEALANT. DRILL 3/16 HOLE THRU CENTER OF PLUG AND ATTACH. CONNECT NOZZLE HARNESS FOR SHIPMENT.
 - 13 USE AGRO "TUF-GLIDE THREAD SEALANT WITH PTFE".

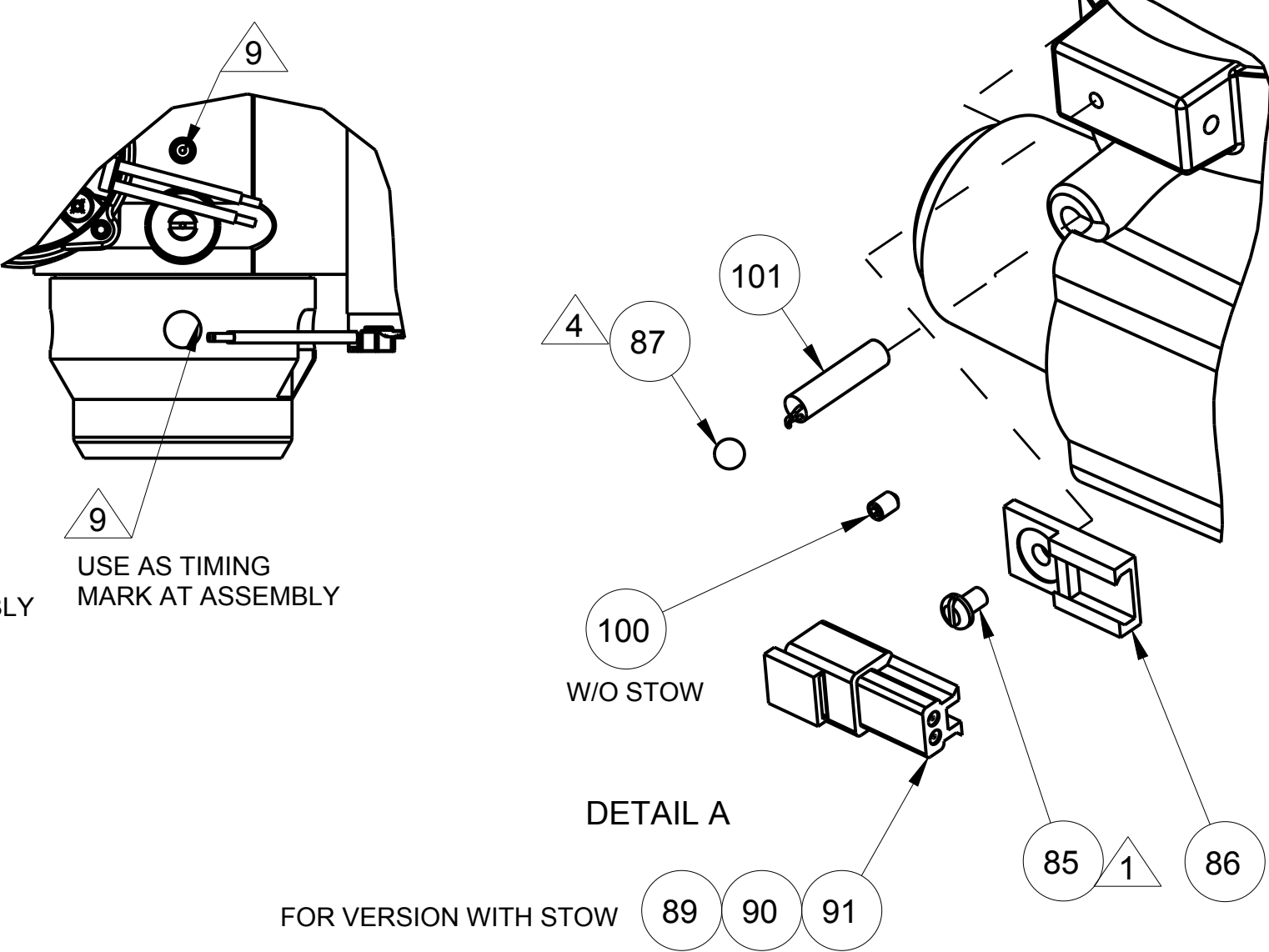

500 GPM VERSION

FOR VERSION WITH STOW

PHONE: 330.264.5678 or 800.228.1161 | FAX: 330.264.2944 or 800.531.7335 | www.akronbrass.com

Parts List Sheet:

117906

WARRANTY AND DISCLAIMER*: We warrant Akron Brass products for a period of five (5) years* after purchase against defects in materials or workmanship. Akron Brass will repair or replace product which fails to satisfy this warranty. Repair or replacement shall be at the discretion of Akron Brass. Products must be promptly returned to Akron Brass for warranty service. We will not be responsible for: wear and tear; any improper installation, use, maintenance or storage; negligence of the owner or user; repair or modification after delivery; failure to follow our instructions or recommendations; or anything else beyond our control. WE MAKE NO WARRANTIES, EXPRESS OR IMPLIED, OTHER THAN THOSE INCLUDED IN THIS WARRANTY STATEMENT, AND WE DISCLAIM ANY IMPLIED WARRANTY OF MERCHANTABILITY OR FITNESS FOR ANY PARTICULAR PURPOSE. Further, we will not be responsible for any consequential, incidental or indirect damages (including, but not limited to, any loss of profits) from any cause whatsoever. No person has authority to change this warranty. *Unless otherwise provided herein. Akron Brass industrial electronic components & the Severe-Duty Monitor have a one (1) year warranty. Select Akron Brass handline nozzles and valves carry a ten (10) year warranty. Scene Star Lights carry a (6) year warranty. Weldon products have a two (2) year warranty from date of manufacture (excluding consumable components). Select Weldon LED products carry a five (5) year warranty. Honda products have the manufacturers' warranty and Akron Brass disclaims any warranty in respect of those products.

© 2016 Akron Brass Company. All rights reserved. No portion of this can be reproduced without the express written consent of the Akron Brass Company.

ASSEMBLY NOTES:

USE PARKER O-LUBE ON ALL O-RINGS AND MATING SURFACES UNLESS OTHERWISE NOTED

- 1 USE PERMABOND LM113 OR LOCTITE 222
- 2 USE LOCTITE 290
- 3 USE LOW-TEMP LUBRIPLATE
- 4 USE SIKAFLEX-1A SEALANT
- 5 DIMPLE AT ASSEMBLY
- 6 GENERIC DEPICTION. SEE BILL OF MATERIALS
- 7 USE ONLY ON U1 VERSIONS (34632XXX DENOTES U2 VERSIONS)
- 8 USE PERMABOND LH050 OR LOCTITE 592
- 9 ALIGN TIMING DIMPLE ON BOTH JOINTS
- 10 ALIGN BALL IN HOLE. TIGHTEN PLUG UNTIL IT TOUCHES BALL. THEN BACK OUT PLUG 1/4-1/2 TURN.
- 11 THIS ITEM NOT USED ON VERSION WITH DRY CHEMICAL NOZZLE. SEE DRY CHEMICAL ASSEMBLY DRAWING (D-41621) FOR INSTALLATION/ASSEMBLY DETAILS.
- 12 CUT WIRES AT CONNECTOR AND SEAL WITH SIKAFLEX-1A SEALANT. DRILL 3/16 HOLE THRU CENTER OF PLUG AND ATTACH. CONNECT NOZZLE HARNESS FOR SHIPMENT.
- 13 USE AGRO "TUF-GLIDE THREAD SEALANT WITH PTFE".

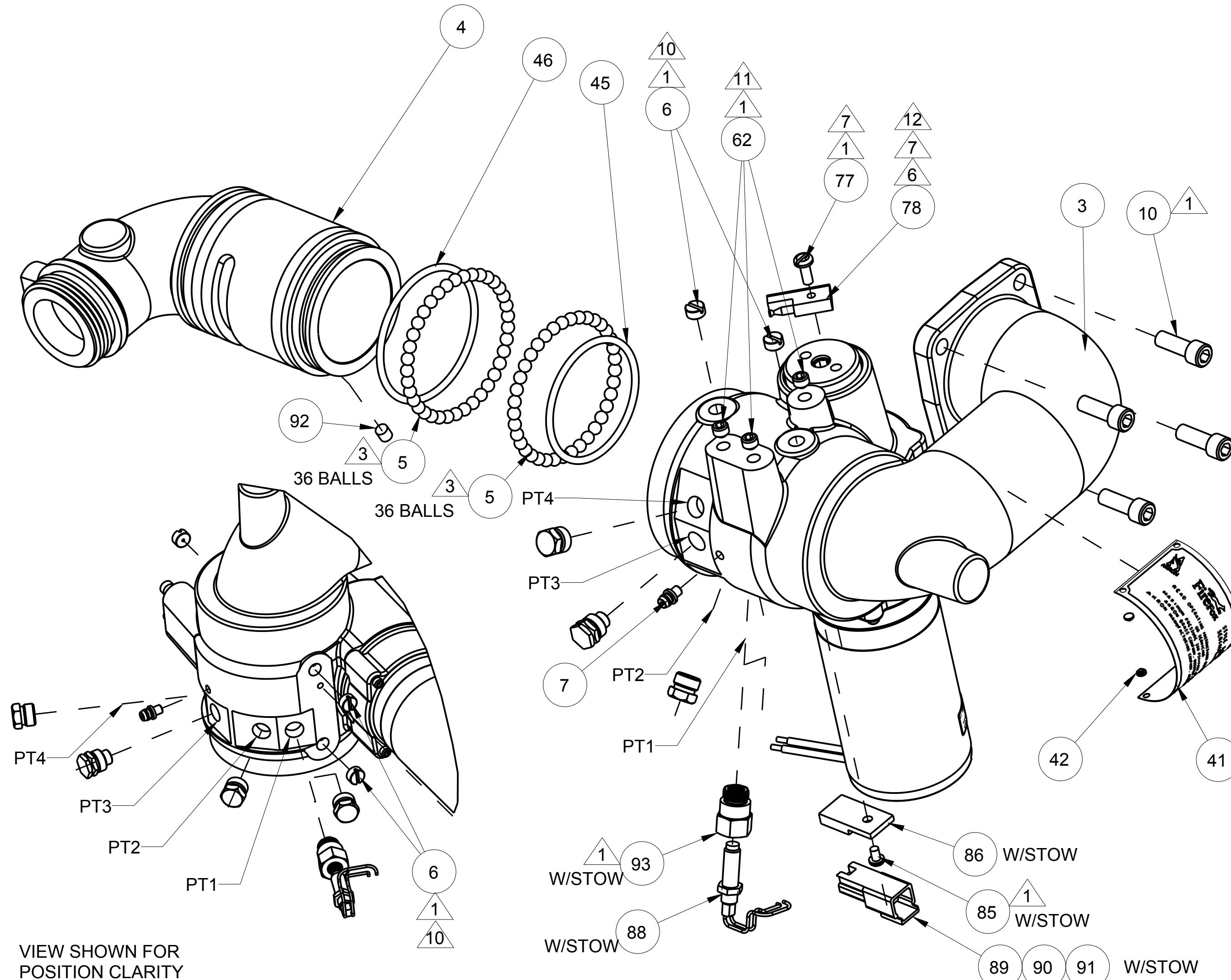

VIEW SHOWN FOR POSITION CLARITY

ELEVATION STOP (ITEM 43) LOCATIONS		
ANGLE OF ROTATION	STOP LOCATIONS	SENSOR LOCATION (WITH STOW) ITEM 93
+90° , -45°	3	1
+45° , -20°	2,4	1
ALL OTHER LOCATIONS (ITEM 44)		

PHONE: 330.264.5678 or 800.228.1161 | FAX: 330.264.2944 or 800.531.7335 | www.akronbrass.com

Parts List Sheet:

117906

WARRANTY AND DISCLAIMER*: We warrant Akron Brass products for a period of five (5) years* after purchase against defects in materials or workmanship. Akron Brass will repair or replace product which fails to satisfy this warranty. Repair or replacement shall be at the discretion of Akron Brass. Products must be promptly returned to Akron Brass for warranty service. We will not be responsible for: wear and tear; any improper installation, use, maintenance or storage; negligence of the owner or user; repair or modification after delivery; failure to follow our instructions or recommendations; or anything else beyond our control. WE MAKE NO WARRANTIES, EXPRESS OR IMPLIED, OTHER THAN THOSE INCLUDED IN THIS WARRANTY STATEMENT, AND WE DISCLAIM ANY IMPLIED WARRANTY OF MERCHANTABILITY OR FITNESS FOR ANY PARTICULAR PURPOSE. Further, we will not be responsible for any consequential, incidental or indirect damages (including, but not limited to, any loss of profits) from any cause whatsoever. No person has authority to change this warranty. *Unless otherwise provided herein. Akron Brass industrial electronic components & the Severe-Duty Monitor have a one (1) year warranty. Select Akron Brass handline nozzles and valves carry a ten (10) year warranty. Scene Star Lights carry a (6) year warranty. Weldon products have a two (2) year warranty from date of manufacture (excluding consumable components). Select Weldon LED products carry a five (5) year warranty. Honda products have the manufacturers' warranty and Akron Brass disclaims any warranty in respect of those products.

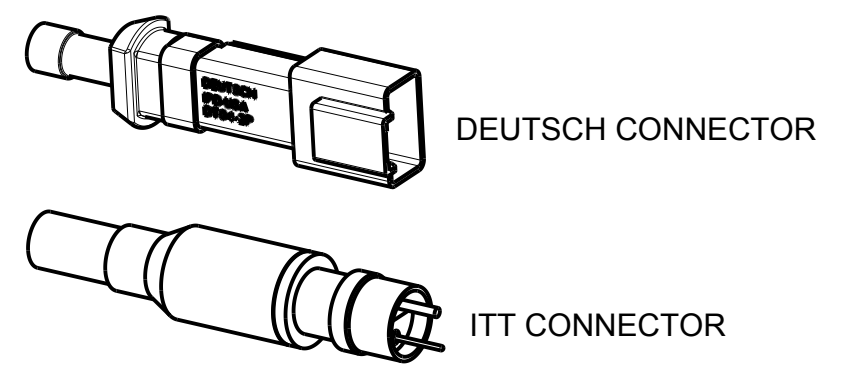
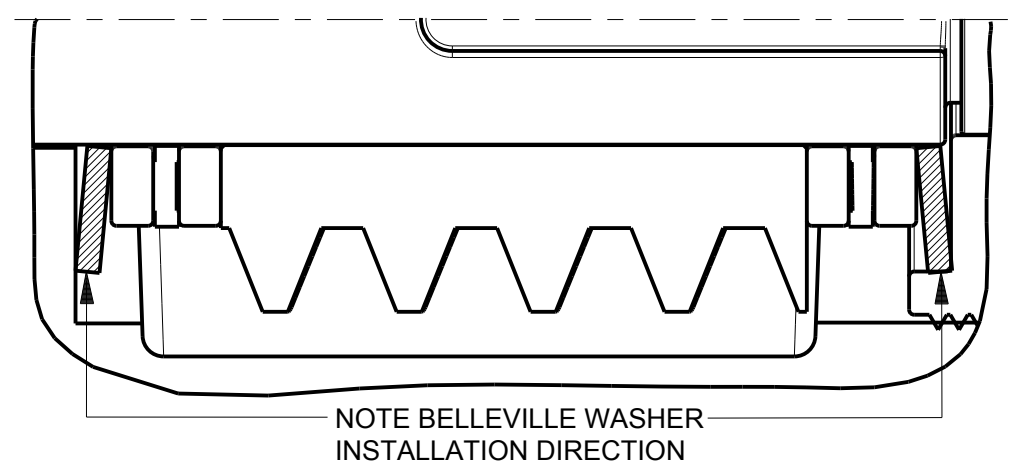
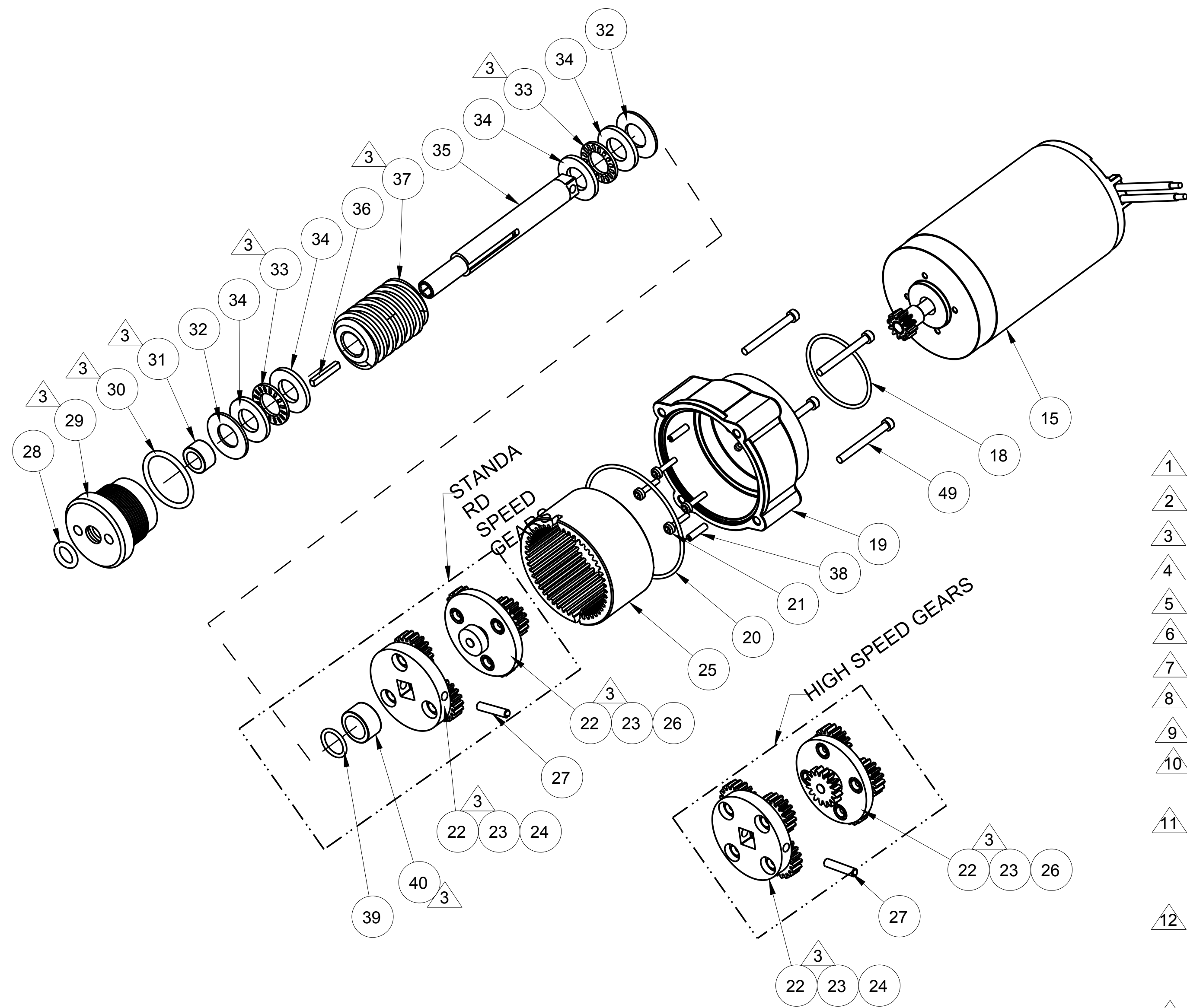

- ASSEMBLY NOTES:**
- USE PARKER O-LUBE ON ALL O-RINGS AND MATING SURFACES UNLESS OTHERWISE NOTED
 - 1 USE PERMABOND LM113 OR LOCTITE 222
 - 2 USE LOCTITE 290
 - 3 USE LOW-TEMP LUBRIPLATE
 - 4 USE SIKAFLEX-1A SEALANT
 - 5 DIMPLE AT ASSEMBLY
 - 6 GENERIC DEPICTION. SEE BILL OF MATERIALS
 - 7 USE ONLY ON U1 VERSIONS (34632XXX DENOTES U2 VERSIONS)
 - 8 USE PERMABOND LH050 OR LOCTITE 592
 - 9 ALIGN TIMING DIMPLE ON BOTH JOINTS
 - 10 ALIGN BALL IN HOLE. TIGHTEN PLUG UNTIL IT TOUCHES BALL. THEN BACK OUT PLUG 1/4-1/2 TURN.
 - 11 THIS ITEM NOT USED ON VERSION WITH DRY CHEMICAL NOZZLE. SEE DRY CHEMICAL ASSEMBLY DRAWING (D-41621) FOR INSTALLATION/ASSEMBLY DETAILS.
 - 12 CUT WIRES AT CONNECTOR AND SEAL WITH SIKAFLEX-1A SEALANT. DRILL 3/16 HOLE THRU CENTER OF PLUG AND ATTACH. CONNECT NOZZLE HARNESS FOR SHIPMENT.
 - 13 USE AGRO "TUF-GLIDE THREAD SEALANT WITH PTFE".

MOTOR/GEARBOX ASSEMBLY
FOR BOTH ELEVATION AND ROTATION JOINTS

PHONE: 330.264.5678 or 800.228.1161 | FAX: 330.264.2944 or 800.531.7335 | www.akronbrass.com

WARRANTY AND DISCLAIMER*: We warrant Akron Brass products for a period of five (5) years* after purchase against defects in materials or workmanship. Akron Brass will repair or replace product which fails to satisfy this warranty. Repair or replacement shall be at the discretion of Akron Brass. Products must be promptly returned to Akron Brass for warranty service. We will not be responsible for: wear and tear; any improper installation, use, maintenance or storage; negligence of the owner or user; repair or modification after delivery; failure to follow our instructions or recommendations; or anything else beyond our control. WE MAKE NO WARRANTIES, EXPRESS OR IMPLIED, OTHER THAN THOSE INCLUDED IN THIS WARRANTY STATEMENT, AND WE DISCLAIM ANY IMPLIED WARRANTY OF MERCHANTABILITY OR FITNESS FOR ANY PARTICULAR PURPOSE. Further, we will not be responsible for any consequential, incidental or indirect damages (including, but not limited to, any loss of profits) from any cause whatsoever. No person has authority to change this warranty. *Unless otherwise provided herein. Akron Brass industrial electronic components & the Severe-Duty Monitor have a one (1) year warranty. Select Akron Brass handline nozzles and valves carry a ten (10) year warranty. Scene Star Lights carry a (6) year warranty. Weldon products have a two (2) year warranty from date of manufacture (excluding consumable components). Select Weldon LED products carry a five (5) year warranty. Honda products have the manufacturers' warranty and Akron Brass disclaims any warranty in respect of those products.

© 2016 Akron Brass Company. All rights reserved. No portion of this can be reproduced without the express written consent of the Akron Brass Company.

Parts List Sheet:
117906

D41510



TECHNICAL SERVICE PARTS

STYLE 3463,3563

PRODUCT FIREFOX

IF AN ITEM IS NOTED AS "NOT FIELD REPAIRABLE", OR YOU WISH TO RETURN AN ITEM TO AKRON BRASS FOR SERVICE PLEASE GO ONLINE TO, ONLINEREPAIR.AKRONBRASS.COM

Chg.	Date
31	08-18
32	02-19

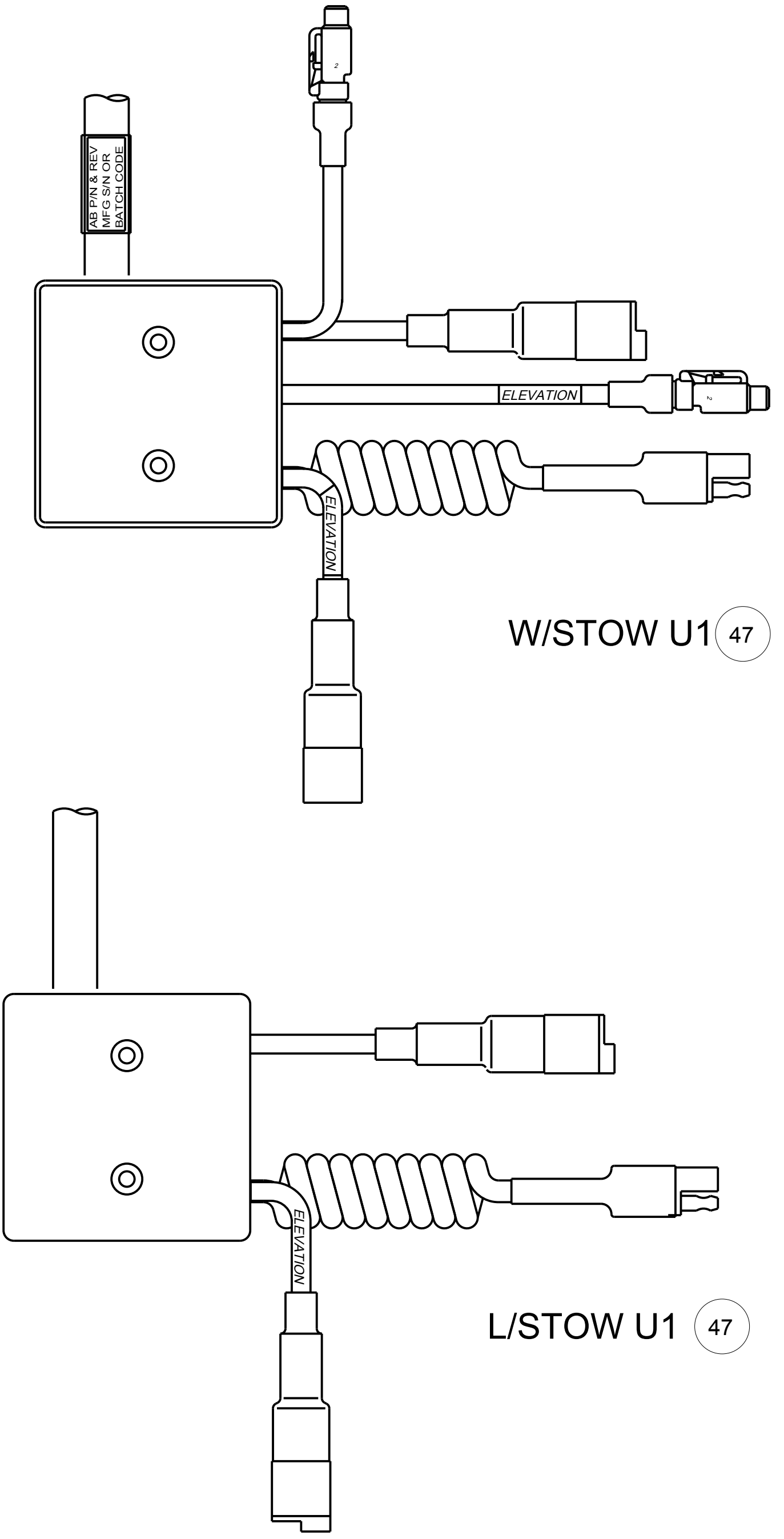
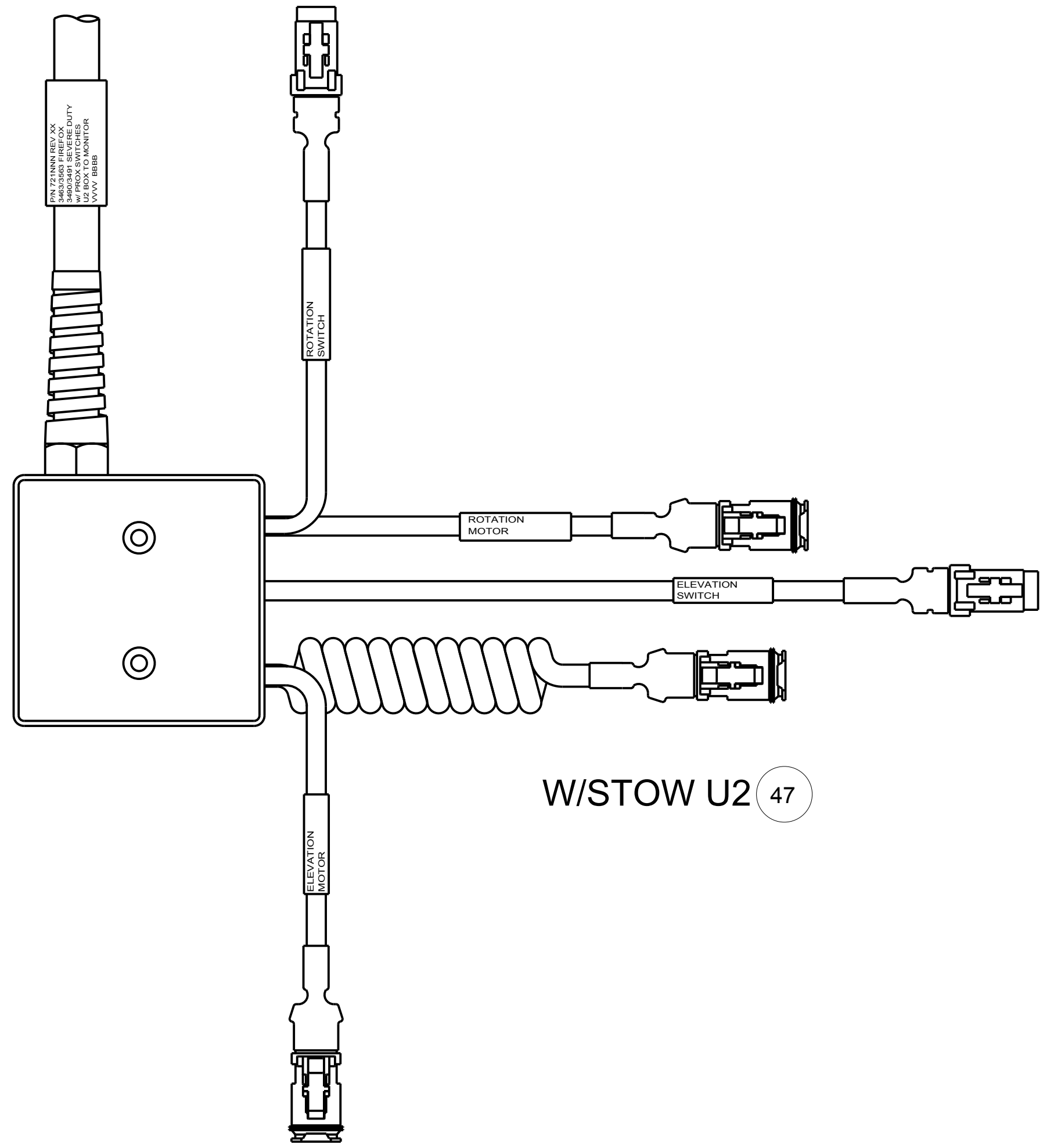

ITEM NO.	DESCRIPTION	ITEM	QUANTITY	LENGTH
47	WIRING HARNESS L/STOW U1	721495	1	8'
47	WIRING HARNESS W/STOW U1	721494	1	8'
47	WIRING HARNESS W/STOW U2	721605	1	2'
47	WIRING HARNESS W/STOW U2	721623	1	8'

PHONE: 330.264.5678 or 800.228.1161 | FAX: 330.264.2944 or 800.531.7335 | www.akronbrass.com

Parts List Sheet:

117906

WARRANTY AND DISCLAIMER*: We warrant Akron Brass products for a period of five (5) years* after purchase against defects in materials or workmanship. Akron Brass will repair or replace product which fails to satisfy this warranty. Repair or replacement shall be at the discretion of Akron Brass. Products must be promptly returned to Akron Brass for warranty service. We will not be responsible for: wear and tear; any improper installation, use, maintenance or storage; negligence of the owner or user; repair or modification after delivery; failure to follow our instructions or recommendations; or anything else beyond our control. WE MAKE NO WARRANTIES, EXPRESS OR IMPLIED, OTHER THAN THOSE INCLUDED IN THIS WARRANTY STATEMENT, AND WE DISCLAIM ANY IMPLIED WARRANTY OF MERCHANTABILITY OR FITNESS FOR ANY PARTICULAR PURPOSE. Further, we will not be responsible for any consequential, incidental or indirect damages (including, but not limited to, any loss of profits) from any cause whatsoever. No person has authority to change this warranty. *Unless otherwise provided herein. Akron Brass industrial electronic components & the Severe-Duty Monitor have a one (1) year warranty. Select Akron Brass handline nozzles and valves carry a ten (10) year warranty. Scene Star Lights carry a (6) year warranty. Weldon products have a two (2) year warranty from date of manufacture (excluding consumable components). Select Weldon LED products carry a five (5) year warranty. Honda products have the manufacturers' warranty and Akron Brass disclaims any warranty in respect of those products.



TECHNICAL SERVICE PARTS
STYLE 3463,3563
PRODUCT FIREFOX

IF AN ITEM IS NOTED AS "NOT FIELD REPAIRABLE", OR YOU WISH TO RETURN AN ITEM TO AKRON BRASS FOR SERVICE PLEASE GO ONLINE TO, **ONLINEREPAIR.AKRONBRASS.COM**

Chg.	Date
31	08-18
32	02-19

FIND	DESCRIPTION	ITEM	3463 STANDARD	3563 +3463 DE-ICE
1	BASE QUICK DICONNECT	117898	1	1
1	BASE 1.5" FLANGE	121064	1	1
1	BASE 2.5 NPT	118124	1	1
2	INLET ELBOW	118207	1	1
3	GOOSENECK	118208	1	1
4	OUTLET ELBOW 1.5"	118209	1	1
4	OUTLET ELBOW 2.5"	118948	1	1
5	A BALL BEARING	-	149	149
6	A SWIVEL PLUG	742023	8	8
7	GREASE FITTING	713191	2	2
8	O-RING 2-233 BUNA-N	757065	3	-
8	O-RING 2-233 VITON	757380	-	3
9	O-RING 2-230 BUNA-N	757110	2	-
9	O-RING 2-230 VITON	757378	-	2
10	SCREW 5/16-18 X 7/8	767048	4	4
15	MOTOR/GEAR 12V S/A U1 RED ITT PLUG	35780011	2	-
15	MOTOR/GEAR 24V S/A U1 RED ITT PLUG	35780095	2	-
15	MOTOR/GEAR 12V S/A U2 RED DEUTSCH PLUG	35982013	2	-
15	MOTOR/GEAR 24V S/A U2 RED DEUTSCH PLUG	35982012	2	-
15	MOTOR/GEAR (FAST) 12V RED DEUTSCH PLUG	34620000	-	2
15	MOTOR/GEAR (FAST) 24V RED DEUTSCH PLUG	34620100	-	2
18	O-RING 2-029	757056	2	2
19	GEARBOX HOUSING	121539	2	2
20	O-RING 2-036 BUNA-N	757312	2	-
20	O-RING 2-036 VITON	757381	-	2
21	SCREW 6-32 X 1-1/2	765052	8	2
22	B,D RIVET SHORT	-	12	16
23	B PLANET GEAR (STANDARD SPEED GEARS)	-	12	-
23	D PLANET GEAR (HIGH SPEED GEARS)	-	-	16
24	B OUTPUT CARRIER (STANDARD SPEED GEARS)	-	2	-
24	D OUTPUT CARRIER (HIGH SPEED GEARS)	-	-	2
25	INTERNAL GEAR	718164	2	2
26	B CARRIER PLATE (STANDARD SPEED GEARS)	-	2	-
26	D CARRIER PLATE (HIGH SPEED GEARS)	-	-	2
27	B,D ROLL PIN 5/32 X 3/4	744118	2	2
28	O-RING 2-110 BUNA-N	757295	2	-
28	O-RING 2-110 VITON	757382	-	2
29	BEARING CAP	116465	2	2
30	O-RING 2-121 BUNA-N	757329	2	-
30	O-RING 2-121 VITON	757383	-	2
31	BEARING #SCE65	704393	2	2
32	SPRING	769276	4	4
33	NEEDLE BEARING	703453	4	4
34	THRUST WASHER	784121	8	8
35	ELEVATION SHAFT	769697	2	2
36	KEY	727044	2	2

FIND	DESCRIPTION	ITEM	3463 STANDARD	3563 +3463 DE-ICE	
37		WORM GEAR	718273	2	2
38		ROLL PIN 1/8 X 1/2	744288	4	4
39		O-RING 2-014 BUNA-N	757041	2	-
39		O-RING 2-014 VITON	757384	-	2
40		NEEDLE BEARING	704395	2	2
41		ID PLATE	745125	1	1
42		GRIP NAIL	736052	4	4
43		STOP	769498	4	4
44		CELCON PLUG	744337	3	3
45		O-RING 2-229 BUNA-N	757205	1	-
45		O-RING 2-229 VITON	757385	-	1
46		O-RING 2-231 BUNA-N	757126	1	-
46		O-RING 2-231 VITON	757379	-	1
47	++	12V & 24V LOGIC BOX U1 W/STOW	34630035	1	-
47	++	LOGIC BOX (BOX ONLY) U1	35780118	1	-
47	++	12V/24V PC BOARD (ONLY) STANDARD U1	34630034	1	-
48		SCREW 10-24 X 2	763077	2	2
49		SCREW 6-32 X 1-3/8	767132	8	8
51		FLANGE 3"	712285	1	-
52		NIPPLE 2.5" NPT	735076	1	-
62		SET SCREW 5/16-18 X 1/4	765071	3	3
77		SCREW NYLON 10-24 X 1/2	767147	1	-
78		SPEED CLIP	707219	1	-
85	C	SCREW 8-32 X 1/4	-	2	2
86	C	MOUNTING CLIP	-	2	2
87	C	RUBBER BALL	-	1	1
88	C	MAGNET SWITCH	-	1	1
89	C	RECEPTACLE DTM04-2P	-	2	2
90	C	CONTACT PIN DEUTSCH	-	4	4
91	C	WEDGE LOCK DEUTSCH	-	2	2
92		MAGNET	731081	2	2
93	C	SENSOR BODY	-	1	1
97		CABLE CLAMP	807139	2	2
98		OVERRIDE HANDLE	721291	1	1
99		HAIRPIN CLIP COTTER	744339	1	1
100		SET SCREW 8-32 X 1/4	765164	1	-
101	C	HAMLIN SWITCH	-	1	1
105		QUICK DISCONNECT	34630001	1	-
201	+	SPACER PLATE	118949	1	1
203	+	SCREW 5/16-18 X 1-1/2	765222	4	4
204		WASHER	784072	2	2

A	KIT OF 50 BALLS 1/4" BRASS	109041
B	STANDARD SPEED GEAR KIT	34400209
C	LIMIT SWITCH KIT	34630067
D	HIGH SPEED GEAR KIT	35630018

+ USED WITH 2.5" OUTLET ONLY
 ++ ELECTRICAL COMPONENTS NOT SHOWN

PHONE: 330.264.5678 or 800.228.1161 | FAX: 330.264.2944 or 800.531.7335 | www.akronbrass.com

Parts List Sheet:

117906

WARRANTY AND DISCLAIMER: We warrant Akron Brass products for a period of five (5) years* after purchase against defects in materials or workmanship. Akron Brass will repair or replace product which fails to satisfy this warranty. Repair or replacement shall be at the discretion of Akron Brass. Products must be promptly returned to Akron Brass for warranty service. We will not be responsible for: wear and tear; any improper installation, use, maintenance or storage; negligence of the owner or user; repair or modification after delivery; failure to follow our instructions or recommendations; or anything else beyond our control. WE MAKE NO WARRANTIES, EXPRESS OR IMPLIED, OTHER THAN THOSE INCLUDED IN THIS WARRANTY STATEMENT, AND WE DISCLAIM ANY IMPLIED WARRANTY OF MERCHANTABILITY OR FITNESS FOR ANY PARTICULAR PURPOSE. Further, we will not be responsible for any consequential, incidental or indirect damages (including, but not limited to, any loss of profits) from any cause whatsoever. No person has authority to change this warranty. *Unless otherwise provided herein. Akron Brass industrial electronic components & the Severe-Duty Monitor have a one (1) year warranty. Select Akron Brass handline nozzles and valves carry a ten (10) year warranty. Scene Star Lights carry a (6) year warranty. Weldon products have a two (2) year warranty from date of manufacture (excluding consumable components). Select Weldon LED products carry a five (5) year warranty. Honda products have the manufacturers' warranty and Akron Brass disclaims any warranty in respect of those products.